

Installation instructions

Induction hob

GK11TIFKZ | GK11TIFKZS | CTI6T96FKTFHD



1032691-09

25/11/2020

 **The appliance should be installed by qualified personnel only. Each step must be carried out and checked in full in the order specified.**

Validity

These installation instructions apply to the following models:

Model designation	Model number	Type	Frameless, for surface-mounted installation	Frameless, for flush installation
GK11TIFK FullFlex	31062	GK11TIFKZ	GK11TIFKZ	GK11TIFKZ
GK11TIFK FullFlex	31062	GK11TIFKZS	GK11TIFKZS	GK11TIFKZS
CookTopInduction V6000 FullFlex	31134	CTI6T-31134	CTI6T96FKTFHD	CTI6T96FKTFHD
CookTop V6000 I906 FullFlex				

General notes

 **If installing into a combustible material, the guidelines and standards for low-voltage installations and fire protection must be strictly observed.**

Identification plate

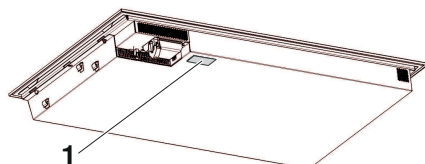

1 Identification plate with serial number (SN)

► Affix the second identification plate (supplied) in an accessible position behind the front of the fitted cabinet beneath the appliance.

Installation accessories supplied

Flush installation:

Designation	Art. no.
Cementing-in instructions	J004133
Sealing strip set	H63283
Spacer set	H60330

Accessories

Flush installation:

Designation	Art. no.
Ventilation protective plate set for niche width 900 mm	H61085
Steel angle set, installation dimension 90	H63775
Intermediate support kit for the flush-mounted combination of several hobs (contains two intermediate supports)	H63789
Instant adhesive for installation of the steel angle (50 ml)	B11657
Straight mixing nozzle	B11656
TREMCLEAN isopropyl alcohol (1000 ml)	1056609
Black silicone FA880 (310 ml)	B11555
Anthracite silicone FA880 (310 ml)	B11556
White silicone FA880 (310 ml)	1031313
Stone grey silicone FA880 (310 ml)	1031314
Marble smoothing agent AA320 (1000 ml)	B11557
Fugenboy (silicone finishing tool)	B75158



Ventilation



A protective plate with seal must be installed with models 31062 and 31134.

In order to guarantee good ventilation, a space of ≥ 10 mm height is necessary beneath the appliance.

1. The rear panel of the base unit must be open around the work surface cut-out to guarantee continuous air circulation through the ventilation slits.
The air must be drawn in from outside the cabinet and be able to circulate freely from inside the cabinet to the hob.
2. Alternatively, a concealed fresh air supply can ensure air circulation inside the cabinet.
In order that enough cold air can be drawn in, there must be a continuous circulation of fresh air that extends outside the cabinet.
The air must be drawn in from outside the cabinet and be able to circulate freely from inside the cabinet to the hob.

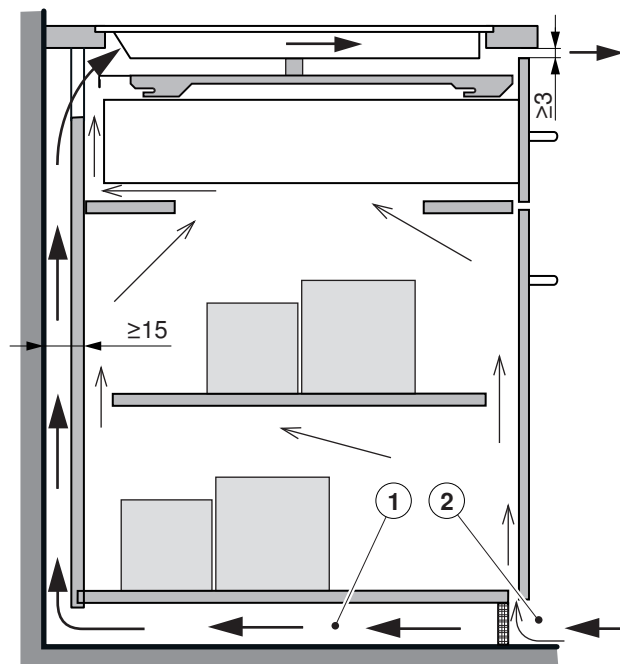



Electrical connection

⚠ Electrical connections must be carried out by qualified personnel in accordance with the guidelines and standards for low-voltage installations and the specifications of the local electricity supply companies. Refer to the identification plate for information on the required mains voltage and current type.

A plug-in appliance may only be connected to a socket outlet with earthing contact, installed according to specifications. An all-pole mains isolating device with 3 mm contact opening should be provided in the house wiring system. Switches, plug and socket devices, circuit breakers and fusible cut-outs which are accessible after installation and which have all-poles switching are permissible as isolating devices. Effective earthing and separately installed neutral and earth conductors ensure safe and fault-free operation. After installation, live parts and cables with basic insulation must not be accessible. Check old installations.

- ▶ If the hobs are used at an altitude of over 2,000 metres, a reduced performance must be expected.
- The appliance is equipped with a connection cable which must be connected to an on-site junction box.

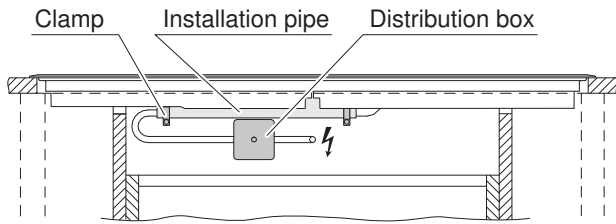

**3106200.../3106203.../3106260.../3106266...
3113400001–3113400003**

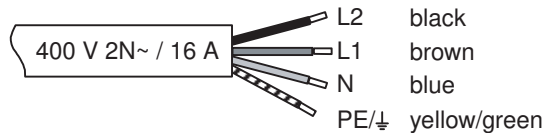
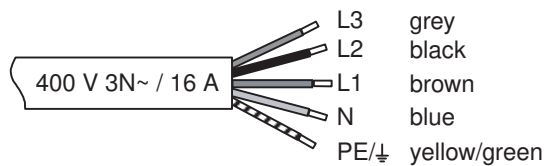

**3106261.../3106265.../3106267...
3113400004**

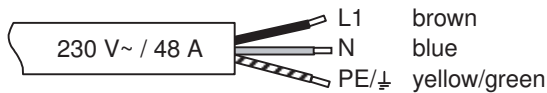

E35/U0 error message

**⚠ Incorrect connection:
Pole conductor connected to connection terminal for neutral conductor.**
Quickly disconnect the appliance from the mains!

General information about installation

⚠ The distance from the appliance cut-out to flammable walls (left, right and rear) must be ≥50 mm. Parts such as side walls and reinforcing strips which protrude into the installation space under the cooking zone must be made of non-combustible materials.
It is recommended that a distance of 20 mm be maintained between the underside of the appliance tray and any part of the cabinet beneath that is made of combustible material. If a drawer is installed directly underneath – and if the tray can be reached from below without the aid of tools – touch protection must be used. The ventilation protective plate set (see Accessories) is recommended for this purpose.

- The worktop must be flat so that it is sufficiently sealed against the ingress of liquids.
- In order to guarantee good ventilation, a space of at least 10 mm in height is necessary beneath the appliance.
- A cabinet element with a width of 900 mm is recommended for the base element.



Surface-mounted installation with DualDesign

The layout of the hob to be fitted may differ from the hob illustrated!

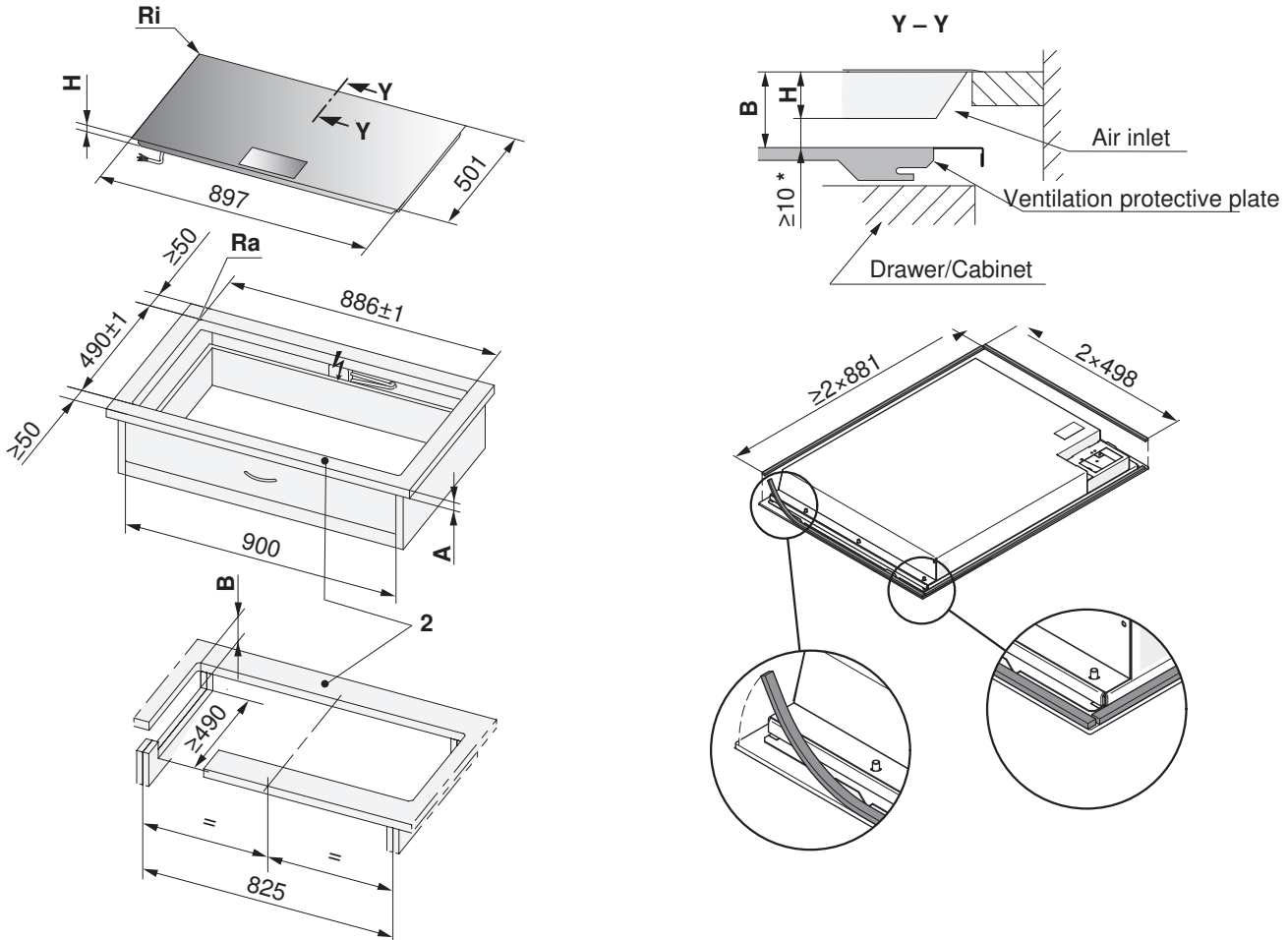

* The required clearance must be observed!

- 2 The front and rear pegs are reinforced underneath. The strut width is determined by the producer of the stone worktop. The minimum peg width can vary according to the properties of the stone.

Type designation	A Depends on producer	B	H	Corner radius Ra/Ri
GK11TIFKZ, GK11TIFKZS CTI6T96FKTFHD	≥40 mm	≥82 mm	72 mm	5/1.5 mm

- A** Worktop depth
- B** Required clearance for service replacement over the entire cut-out area.
- H** Dimension from the top of the work surface to the underside of the hob
- Ri** Corner radii of appliance
- Ra** Outer corner radii of cut-out

Installation

1. Create an accurate installation cut-out.
2. Stick the sealing tape to the underside of the glass.
3. Carefully put the appliance in the installation cut-out and press against the worktop with sufficient overlap.



Flush installation with DualDesign

The layout of the hob to be fitted may differ from the hob illustrated!

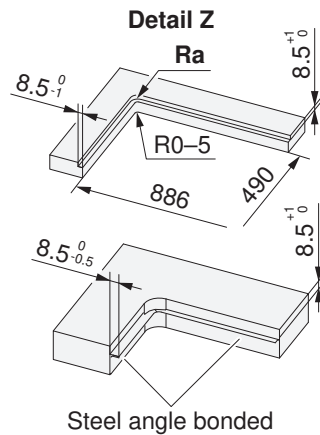
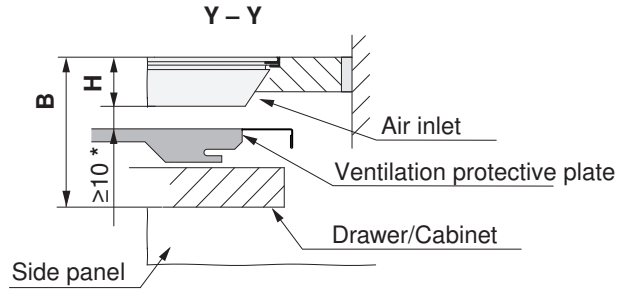
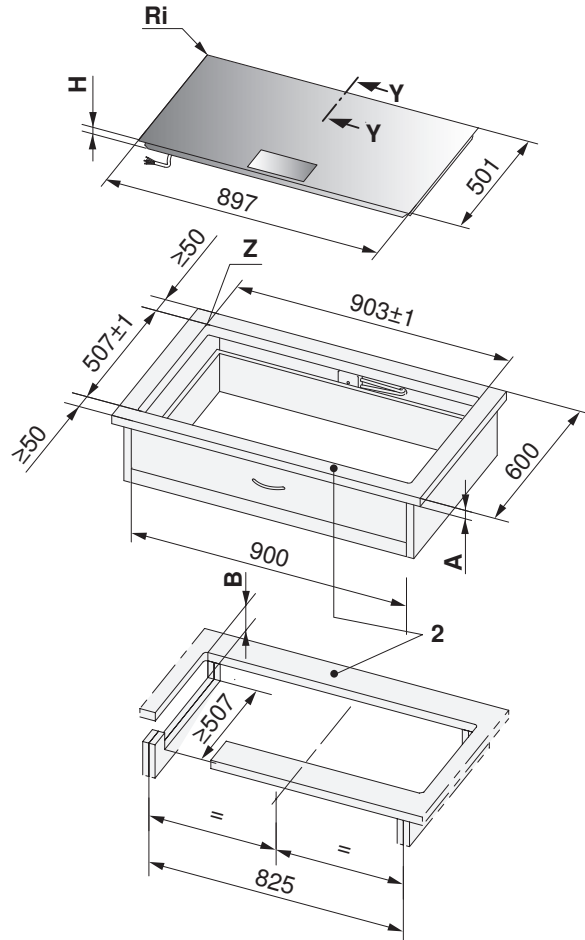

* The required clearance must be observed!

2 The front and rear pegs are reinforced underneath. The strut width is determined by the producer of the stone worktop. The minimum peg width can vary according to the properties of the stone.

Type designation	A Depends on producer	B	H	Corner radius Ra/Ri
GK11TIFKZ, GK11TIFKZS CTI6T96FKTFHD	≥40 mm	≥150 mm	76 mm	5/1.5 mm

A Worktop depth

B Required clearance for service replacement over the entire cut-out area.

H Dimension from the top of the work surface to the underside of the hob

Ri Corner radii of appliance

Ra Outer corner radii of cut-out

Installation

1. Create an accurate installation cut-out.

- The mounting surface can be reamed out or created by installing wood/stone supports or using the steel angle set (see Accessories).



Access to the appliance from below via the entire cut-out area must be guaranteed. For servicing purposes, the induction generator can be removed from below with the mounting plate. It must be possible to unscrew the contact-proof covers from below.

2. Prepare the cut-out and appliance in accordance with the specifications in the enclosed cementing-in instructions.
3. Carefully cement the appliance in and leave the silicone sealant to dry for at least 24 hours.
4. Connect to the electrical mains connection before inserting the appliance, if necessary.



Installation of the ventilation protective plate with 3 mm ventilation gap at the front



A protective plate with seal is necessary for the adequate ventilation of the hob.
The distance X between the underside of the appliance and the protective plate must be ≥ 10 mm.

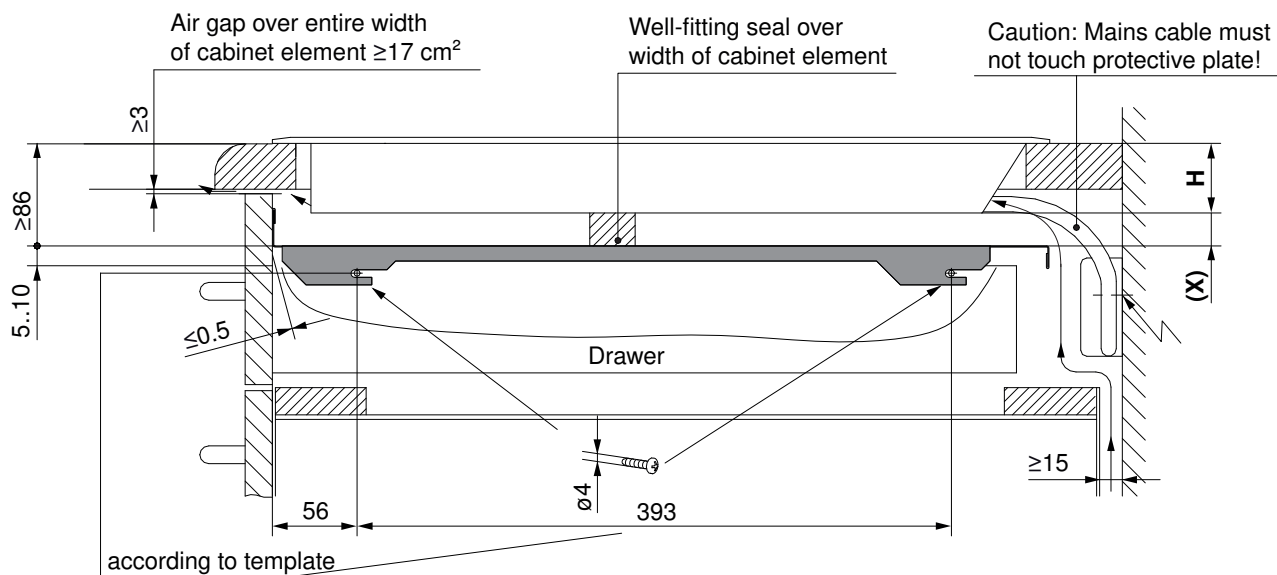

Type designation	X	H	Remarks
GK11TIFKZ, GK11TIFKZS, CTI6T96FKTFHD	14 mm	72 mm	Surface-mounted installation
GK11TIFKZ, GK11TIFKZS, CTI6T96FKTFHD	10 mm	76 mm	Flush installation

H Dimension from the top of the work surface to the underside of the hob (ventilation opening).